

Your purchase of **BALVER ZINN®** alloy entitles you to bath analysis. To take advantage of this service simply take a sample of your solder bath and return (include sheet page 2) to us. Within 24 hours of receipt in the laboratory you will receive full results including error limits enabling early corrective action should this be necessary.

Sampling

Sampling technique may influence the results of the analysis and how these relate to your solder bath. Sensible precautions are summarized below.



Use clean tools and moulds. Carefully separate leaded and lead free alloys



- The solder bath must be at minimum operating temperature.
- The solder bath must be well mixed. *It is best to sample from a running wave just before the end of production.*
- For sampling use a clean and preheated steel spoon. Samples must always be formed in a cold mould. *We will provide a sample form on request.*
- The solder bath test must the dimensions indicated here. *We reserve the right to charge for reworking of alloy samples if this is necessary.*

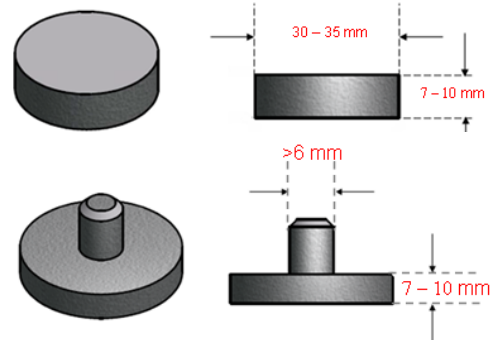

Documentation

To avoid confusion and incorrect assignments, the following items are required.

on sample



on delivery documents



	on sample	on delivery documents
Customer	X	X
Agents / ISO-Country-Code (optional)		X
Date of sampling	X	X
Equipment (example: Seho GoWave...) (optional)	X	X
Equipment type (Wave soldering, HASL...)		X
Unique installation assignment (ex. InventoryNo.)	X	X
Base alloy (example: SN100C)		X
Top-up alloy (example: SN100Ce)		X
Contact (eMail) for results		X

Shipping

Transport packaging should be secure, but minimize environmental impact by avoiding packaging waste.

Send your sample to the following address:

BALVER ZINN®

Josef Jost GmbH & Co. KG
 Abt.: Labor
 Auf dem Werenfelde 11
 DE-58802 Balve

Sheet for sample

Customer / Place		Please specify source of sample if more than one company location exists
Agents / ISO-Country-Code		(optional) Country of origin of the sample. Indication as ISO country code
Date of sampling		
Equipment designation		Example: Seho GoWave
Equipment type	Wave Soldering <input type="checkbox"/>	Used to select the limits and recommendations
	Selective Soldering <input type="checkbox"/>	
	Hot Air Solder Levelling <input type="checkbox"/>	
	Other <input type="checkbox"/>	
Unique installation assignment		Example: Inventory Number
Base alloy		Name of the alloy Example: SN100Ce
Top-up alloy		
Contact (eMail)		Please enter <u>one</u> contact email for analysis.
Remarks		